

SR22

G1 OR G2



Quick Reference Checklist

for

SR22 Aircraft Serials 0002 thru 2333, 2335 thru 2419,
and 2421 thru 2437.



CIRRUS
A I R C R A F T

The procedures in this publication are abbreviated and derived from procedures in the FAA Approved Airplane Flight Manual and Pilot's Operating Handbook (POH) P/N 13772-001 Revision A10 Release. These procedures do not supersede the procedures in the basic POH. In the event of conflict, the basic POH shall take precedence.

CIRRUS PILOT'S CHECKLIST MODEL SR22

Normal Procedures Table of Contents

Primary Flight Display	N-1
Airspeeds for Normal Operation	N-2
Preflight Inspection	N-3
Before Starting Engine	N-6
Starting Engine	N-7
Before Taxiing	N-7
Taxiing	N-7
Before Takeoff	N-8
Normal Takeoff	N-9
Short Field Takeoff	N-9
Climb	N-9
Cruise	N-9
Cruise Leaning	N-10
Descent	N-10
Before Landing	N-10
Balked Landing/Go-Around	N-10
After Landing	N-11
Shutdown	N-11

Primary Flight Display

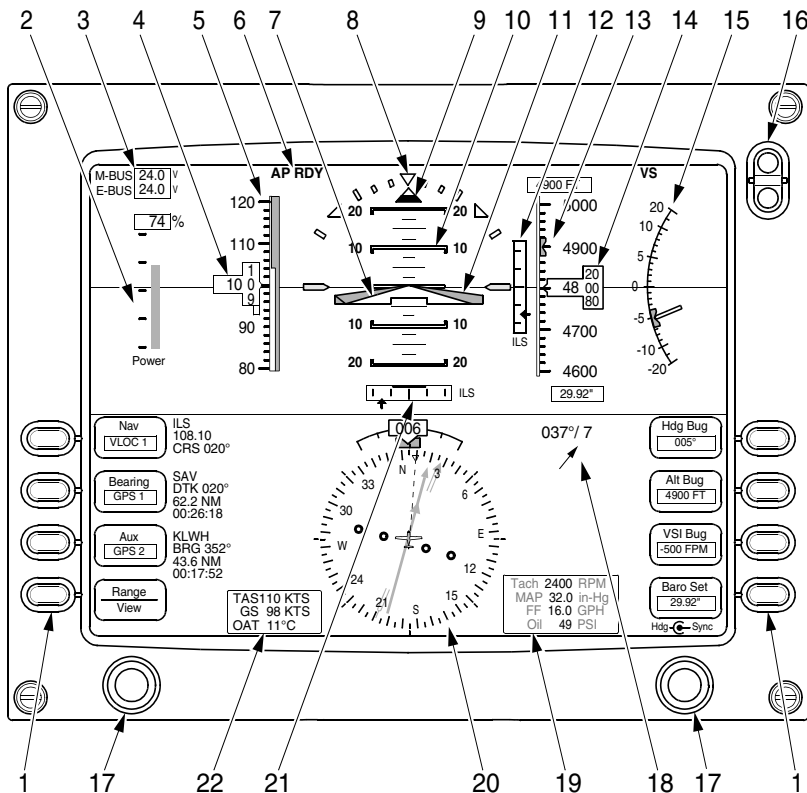

LEGEND

- | | |
|--|--|
| 1. Navigation & Avionics Configuration Buttons | 12. Vertical Deviation Indicator (VDI) |
| 2. Percent Power | 13. Altitude Tape |
| 3. Bus Voltages | 14. Altitude Window |
| 4. Airspeed Window | 15. Vertical Speed Indicator (VSI) |
| 5. Airspeed Tape | 16. Brightness Control (BRT/DIM) |
| 6. Autopilot Annunciations | 17. Mode and Display Selection |
| 7. Aircraft Reference Symbol | 18. Wind Vector |
| 8. Bank Angle Indicator | 19. Engine Information Data Block |
| 9. Skid/Slip Indicator | 20. Horizontal Situation Indicator (HSI) |
| 10. Pitch Ladder | 21. Horizontal Deviation Indicator (HDI) |
| 11. Flight Director Steering Command Bars | 22. Air Data Block |

SR22_FM07_2221A

Airspeeds for Normal Operation

Takeoff Rotation:

- Normal, Flaps 50%..... 70 KIAS
- Obstacle Clearance, Flaps 50%..... 78 KIAS

Enroute Climb, Flaps Up:

- Normal..... 110-120 KIAS
- Best Rate of Climb, SL 101 KIAS
- Best Rate of Climb, 10,000' 95 KIAS
- Best Angle of Climb, SL..... 78 KIAS
- Best Angle of Climb, 10,000' 82 KIAS

Landing Approach:

- Normal Approach, Flaps Up..... 90-95 KIAS
- Normal Approach, Flaps 50% 85-90 KIAS
- Normal Approach, Flaps 100% 80-85 KIAS
- Short Field, Flaps 100% (VREF)..... 77 KIAS

Go-Around, Flaps 50%:

- Full Power..... 80 KIAS

Maximum Recommended Turbulent Air Penetration:

- 3400 Lb 133 KIAS
- 2900 Lb 123 KIAS

Maximum Demonstrated Crosswind

- Takeoff or Landing 20 Knots

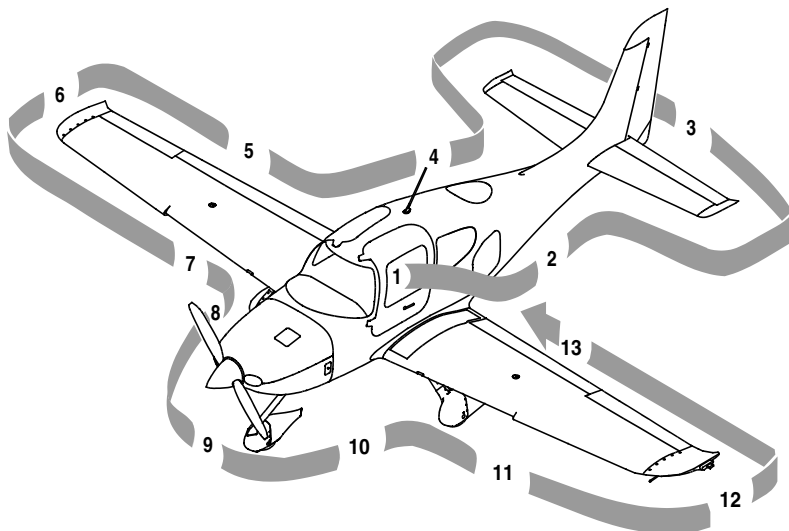

SR20_FM04_1001

Preflight Inspection

1. Cabin

- a. Required Documents On Board
- b. Avionics Power Switch OFF
- c. Bat 2 Master Switch ON
- d. PFD - Serials 0435 and subsequent with PFD.....Verify On
- e. Avionics Cooling Fan..... Audible
- f. Voltmeter 23-25 Volts
- g. Flap Position LightOUT
- h. Bat 1 Master Switch ON
- i. Lights..... Check Operation
- j. Stall Warning Test
- k. Fuel Quantity Check
- l. Fuel Selector Select Fullest Tank
- m. Flaps 100%, Check Light ON
- n. Oil Annunciator.....On
- o. Bat 1 and 2 Master Switches OFF

CIRRUS PILOT CHECKLIST

MODEL SR22

- p. Alternate Static Source NORMAL
- q. Circuit Breakers..... IN
- r. Fire Extinguisher Charged and Available
- s. Emergency Egress Hammer Available
- t. CAPS Handle Pin Removed
- 2. Left Fuselage
 - a. Door Lock..... Unlock
 - b. COM 1 Antenna (top) Condition and Attachment
 - c. Wing/Fuselage Fairing Check
 - d. COM 2 Antenna (underside) Condition and Attachment
 - e. Baggage Door Closed and Secure
 - f. Static Button..... Check for Blockage
 - g. Parachute Cover Sealed and Secure
- 3. Empennage
 - a. Tiedown Rope Remove
 - b. Horizontal and Vertical Stabilizers..... Condition
 - c. Elevator and Tab Condition and Movement
 - d. Rudder Freedom of Movement
 - e. Rudder Trim Tab..... Condition and Security
 - f. Attachment hinges, bolts and cotter pins Secure
- 4. Right Fuselage
 - a. Static Button..... Check for Blockage
 - b. Wing/Fuselage Fairings Check
 - c. Door Lock..... Unlock
- 5. Right Wing Trailing Edge
 - a. Flap and Rub Strips (if installed) Condition and Security
 - b. Aileron and Tab Condition and Movement
 - c. Aileron Gap Seal Security
 - d. Hinges, actuation arm, bolts, and cotter pins Secure
- 6. Right Wing Tip
 - a. Tip Attachment
 - b. Strobe, Nav Light and Lens..... Condition and Security

(Continued on following page)

CIRRUS

PILOT CHECKLIST

MODEL SR22

- c. Fuel Vent (underside)..... Unobstructed
- 7. Right Wing Forward and Main Gear
 - a. Leading Edge and Stall Strips..... Condition
 - b. Fuel Cap..... Check Quantity and Secure
 - c. Fuel Drains (2 underside)..... Drain and Sample
 - d. Wheel Fairings Security, Accumulation of Debris
 - e. Tire Condition, Inflation, and Wear
 - f. Wheel and Brakes Fluid Leaks, Evidence of Overheating, General Condition, and Security
 - g. Chocks and Tiedown Ropes Remove
 - h. Cabin Air Vent Unobstructed
- 8. Nose, Right Side
 - a. Vortex Generator Condition
 - b. Cowling Attachments Secure
 - c. Exhaust Pipe Condition, Security, and Clearance
 - d. Transponder Antenna (underside)... Condition and Attachment
 - e. Gascolator (underside)..... Drain for 3 seconds, Sample
- 9. Nose gear, Propeller, and Spinner
 - a. Tow Bar Remove and Stow
 - b. Strut..... Condition
 - c. Wheel Fairing Security, Accumulation of Debris
 - d. Wheel and Tire Condition, Inflation, and Wear
 - e. Propeller..... Condition (indentations, nicks, etc.)
 - f. Spinner..... Condition, Security, and Oil Leaks
 - g. Air Inlets Unobstructed
 - h. Alternator Condition
- 10. Nose, Left Side
 - a. Landing Light..... Condition
 - b. Engine Oil..... Check 6-8 quarts, Leaks, Cap & Door Secure
 - c. Cowling Attachments Secure
 - d. External Power Door Secure
 - e. Vortex Generator..... Condition
 - f. Exhaust Pipe(s)..... Condition, Security, and Clearance

- 11. Left Main Gear and Forward Wing
 - a. Wheel fairingsSecurity, Accumulation of Debris
 - b. Tire Condition, Inflation, and Wear
 - c. Wheel and Brakes Fluid Leaks, Evidence of Overheating, General Condition, and Security
 - d. Chocks and Tiedown Ropes Remove
 - e. Fuel Drains (2 underside).....Drain and Sample
 - f. Cabin Air Vent Unobstructed
 - g. Fuel Cap..... Check Quantity and Secure
 - h. Leading Edge and Stall Strips..... Condition
- 12. Left Wing Tip
 - a. Fuel Vent (underside).....Unobstructed
 - b. Pitot Mast (underside) Cover Removed, Tube Clear
 - c. Strobe, Nav Light and Lens Condition and Security
 - d. Tip Attachment
- 13. Left Wing Trailing Edge
 - a. Flap And Rub Strips (If installed) Condition and Security
 - b. Aileron Freedom of movement
 - c. Aileron Gap Seal Security
 - d. Hinges, actuation arm, bolts, and cotter pins Secure

Before Starting Engine

- 1. Preflight Inspection COMPLETED
- 2. Emergency Equipment ON BOARD
- 3. Passengers BRIEFED
- 4. Seats, Seat Belts, and Harnesses ADJUST & SECURE

CIRRUS PILOT CHECKLIST MODEL SR22

Starting Engine

1. External Power (If applicable)CONNECT
2. Brakes HOLD
3. Bat Master SwitchesON (Check Volts)
4. Strobe Lights ON
5. MixtureFULL RICH
6. Power Lever FULL FORWARD
7. Fuel Pump PRIME, then BOOST
8. Propeller Area CLEAR
9. Power Lever OPEN ¼ INCH
10. Ignition SwitchSTART (Release after engine starts)
11. Power Lever RETARD (to maintain 1000 RPM)
12. Oil Pressure CHECK
13. Alt Master Switches ON
14. Avionics Power Switch ON
15. Engine Parameters MONITOR
16. External Power (If applicable)DISCONNECT
17. Amp Meter/Indication CHECK

Before Taxiing

1. Flaps UP (0%)
2. Radios/AvionicsAS REQUIRED
3. Cabin Heat/Defrost AS REQUIRED
4. Fuel Selector SWITCH TANK

Taxiing

1. Parking Brake DISENGAGE
2. BrakesCHECK
3. HSI Orientation CHECK
4. Attitude Gyro CHECK
5. Turn CoordinatorCHECK

Before Takeoff

1. Doors LATCHED
2. CAPS Handle Verify Pin Removed
3. Seat Belts and Shoulder Harness SECURE
4. Air Conditioner AS DESIRED
5. Fuel Quantity CONFIRM
6. Fuel Selector FULLEST TANK
7. Fuel Pump BOOST
8. Mixture AS REQUIRED
9. Flaps SET 50% & CHECK
10. Transponder SET
11. Autopilot CHECK
12. Navigation Radios/GPS SET for Takeoff
13. Cabin Heat/Defrost AS REQUIRED
14. Brakes HOLD
15. Power Lever 1700 RPM
16. Alternator CHECK
 - a. Pitot Heat ON
 - b. Navigation Lights ON
 - c. Landing Light ON
 - d. Annunciator Lights CHECK
17. Voltage CHECK
18. Pitot Heat AS REQUIRED
19. Navigation Lights AS REQUIRED
20. Landing Light AS REQUIRED
21. Magnetos CHECK Left and Right
 - a. RPM drop ≤ 150 , difference between mags ≤ 75 RPM.
22. Engine Parameters CHECK
23. Power Lever 1000 RPM
24. Flight Instruments, HSI, and Altimeter CHECK & SET
25. Flight Controls FREE & CORRECT
26. Trim SET Takeoff
27. Autopilot DISCONNECT

BEFORE TAKEOFF

CIRRUS PILOT CHECKLIST MODEL SR22

Normal Takeoff

1. Brakes..... RELEASE (Steer with Rudder Only)
2. Power Lever FULL FORWARD
3. Engine ParametersCHECK
4. Elevator Control ROTATE Smoothly at 70-73 KIAS
5. At 80 KIAS, Flaps UP

Short Field Takeoff

1. Flaps 50%
2. Brakes HOLD
3. Power Lever FULL FORWARD
4. Mixture SET
5. Engine ParametersCHECK
6. Brakes..... RELEASE (Steer with Rudder Only)
7. Elevator ControlROTATE Smoothly at 70 KIAS
8. Airspeed at Obstacle 78 KIAS

Climb

1. Climb Power..... SET
2. Flaps Verify UP
3. Mixture LEAN as required for altitude
4. Engine ParametersCHECK
5. Fuel PumpBOOST

Cruise

1. Fuel Pump OFF
2. Cruise Power SET
3. Mixture LEAN as required
4. Engine Parameters MONITOR
5. Fuel Flow and Balance MONITOR

Cruise Leaning

Mixture Description	Exhaust Gas Temperature
Best Power	75° F Rich Of Peak EGT
Best Economy	50° F Lean Of Peak EGT

Descent

1. Altimeter SET
2. Cabin Heat/Defrost AS REQUIRED
3. Landing Light ON
4. Fuel System CHECK
5. Mixture AS REQUIRED
6. Brake Pressure CHECK

Before Landing

1. Seat Belt and Shoulder Harness SECURE
2. Fuel Pump BOOST
3. Mixture AS REQUIRED
4. Flaps AS REQUIRED
5. Autopilot AS REQUIRED

Balked Landing/Go-Around

1. Autopilot DISENGAGE
2. Power Lever FULL FORWARD
3. Flaps 50%
4. Airspeed 75-80 KIAS
After clear of obstacles:
5. Flaps UP

CIRRUS PILOT CHECKLIST

MODEL SR22

After Landing

1. Power Lever 1000 RPM
2. Fuel Pump OFF
3. Flaps UP
4. Transponder STBY
5. Lights AS REQUIRED
6. Pitot Heat OFF

Shutdown

1. Fuel Pump (if used) OFF
2. Throttle IDLE
3. Ignition Switch CYCLE - MAG GROUNDING CHECK
4. Mixture CUTOFF
5. All Switches OFF
6. Magnetos OFF
7. ELT TRANSMIT LIGHT OUT
8. Chocks, Tie-downs, Pitot Covers AS REQUIRED

CIRRUS PILOT'S CHECKLIST MODEL SR22

Performance

Table of Contents

Takeoff Distance: 3400 LB.....	P-1
Takeoff Distance: 2900 LB.....	P-2
Cruise Performance	P-3
Landing Distance	P-5
Wind Components	P-6
Weight and Balance	P-7
Loading Calculations	P-7
Loading Data	P-8
Moment Limits	P-8
Temperature Conversion	P-9

• Note •

Aircraft with optional Air Conditioning System; Brake Horsepower is reduced by approximately 6 BHP.

CIRRUS PILOT CHECKLIST

MODEL SR22

Takeoff Distance: 3400 LB

<p>WEIGHT = 3400 LB Speed at Liftoff = 73 KIAS Speed over 50 Ft. Obstacle = 78 KIAS Flaps - 50% · Takeoff Pwr · Dry Paved</p>	<p>Headwind: Subtract 10% for each 12 knots headwind. Tailwind: Add 10% for each 2 knots tailwind up to 10 knots. Runway Slope: Ref. Factors. Dry Grass: Add 20% to Ground Roll. Wet Grass: Add 30% to Ground Roll. Air Conditioner: Add 100' to ground roll and 150' to distance over 50' obstacle if Air Conditioner if ON during takeoff.</p>
--	---

PRESS ALT FT	DISTANCE FT	TEMPERATURE ~ °C					ISA
		0	10	20	30	40	
SL	Grnd Roll	917	990	1067	1146	1229	1028
	50 ft	1432	1539	1650	1764	1883	1594
1000	Grnd Roll	1011	1092	1176	1264	1355	1117
	50 ft	1574	1691	1813	1939	2069	1728
2000	Grnd Roll	1116	1206	1299	1395	1496	1215
	50 ft	1732	1861	1995	2133	2276	1874
3000	Grnd Roll	1234	1332	1435	1542	1653	1323
	50 ft	1907	2049	2196	2349	2507	2035
4000	Grnd Roll	1365	1474	1588	1706	1829	1441
	50 ft	2102	2259	2422	2590	2764	2212
5000	Grnd Roll	1512	1633	1758	1889	2025	1572
	50 ft	2320	2493	2673	2858	3051	2407
6000	Grnd Roll	1676	1810	1950	2095	2245	1717
	50 ft	2564	2755	2953	3159	3371	2622
7000	Grnd Roll	1861	2009	2164	2325	2492	1877
	50 ft	2837	3048	3267	3494	3729	2859
8000	Grnd Roll	2068	2233	2405	2584	2770	2054
	50 ft	3142	3376	3619	3871	4131	3122
9000	Grnd Roll	2302	2485	2677	2875	3082	2250
	50 ft	3485	3744	4014	4293	4581	3412
10000	Grnd Roll	2564	2769	2982	3204	3434	2468
	50 ft	3870	4158	4457	4767	5088	3733

CIRRUS PILOT CHECKLIST

MODEL SR22

Takeoff Distance: 2900 LB

WEIGHT = 2900 LB Speed at Ltoff = 70 KIAS Speed over 50 Ft Obstacle = 74 KIAS Flaps - 50% · Takeoff Pwr · Dry Paved			Headwind: Subtract 10% for each 12 knots headwind. Tailwind: Add 10% for each 2 knots tailwind up to 10 knots. Runway Slope: Ref. Factors. Dry Grass: Add 20% to Ground Roll. Wet Grass: Add 30% to Ground Roll. Air Conditioner: Add 100' to ground roll and 150' to distance over 50' obstacle if Air Conditioner if ON during takeoff.				
PRESS ALT FT	DISTANCE FT	TEMPERATURE ~ °C					
		0	10	20	30	40	ISA
SL	Grnd Roll	610	659	710	763	818	684
	50 ft	971	1043	1118	1195	1275	1080
1000	Grnd Roll	673	727	783	841	902	743
	50 ft	1066	1146	1228	1313	1401	1170
2000	Grnd Roll	743	802	864	929	995	809
	50 ft	1173	1260	1351	1444	1541	1269
3000	Grnd Roll	821	887	955	1026	1100	880
	50 ft	1292	1388	1487	1590	1697	1378
4000	Grnd Roll	908	981	1057	1135	1217	959
	50 ft	1424	1530	1639	1753	1871	1498
5000	Grnd Roll	1006	1086	1170	1257	1348	1046
	50 ft	1571	1688	1809	1935	2065	1630
6000	Grnd Roll	1116	1205	1298	1394	1494	1143
	50 ft	1736	1865	1999	2138	2281	1775
7000	Grnd Roll	1238	1337	1440	1547	1659	1249
	50 ft	1920	2063	2211	2365	2523	1936
8000	Grnd Roll	1376	1486	1601	1720	1843	1367
	50 ft	2127	2285	2449	2619	2795	2113
9000	Grnd Roll	1532	1654	1781	1914	2051	1498
	50 ft	2359	2534	2716	2904	3099	2309
10000	Grnd Roll	1707	1843	1985	2132	2285	1643
	50 ft	2619	2814	3016	3225	3441	2527

TAKEOFF 2900 LB

Cruise Performance

Conditions:

- Cruise Weight 2900 LB
- Winds Zero
- Shaded Cells: Cruise Pwr above 85% not recommended.

• Note •

Subtract 10 KTAS if nose wheel pant and fairing removed. Lower KTAS by 10% if nose and main wheel pants & fairings are removed.

Aircraft with optional Air Conditioning System - Cruise performance is reduced by 2 knots. For maximum performance, the air-conditioner should be off.

Press Alt			ISA - 30°C			ISA			ISA + 30°C		
	RPM	MAP	PWR	KTAS	GPH	PWR	KTAS	GPH	PWR	KTAS	GPH
2000	2700	27.4	103%	186	24.6	98%	186	23.3	93%	181	22.0
	2600	27.4	99%	183	23.5	94%	183	22.2	89%	178	21.5
	2500	27.4	93%	179	22.1	88%	179	20.9	84%	174	20.8
	2500	26.4	89%	176	21.1	84%	176	19.9	80%	171	20.2
	2500	25.4	84%	173	20.0	80%	173	19.0	76%	168	19.5
	2500	24.4	80%	170	19.0	76%	170	18.0	72%	165	18.8
	2500	23.4	76%	167	18.0	72%	167	17.0	68%	162	18.1
4000	2700	25.4	96%	185	22.9	91%	185	21.6	87%	180	20.8
	2600	25.4	92%	182	21.9	87%	182	20.7	83%	177	20.6
	2500	25.4	87%	178	20.6	82%	178	19.5	78%	173	19.9
	2500	24.4	82%	175	19.5	78%	175	18.5	74%	170	19.2
	2500	23.4	78%	172	18.5	74%	172	17.5	70%	167	18.5
	2500	22.4	73%	169	17.4	69%	169	16.5	66%	163	17.7
	2500	21.4	69%	165	16.4	65%	165	15.5	62%	159	16.9
6000	2700	23.5	89%	184	21.2	85%	184	20.1	81%	179	19.6
	2600	23.5	85%	181	20.3	81%	181	19.2	77%	176	19.1
	2500	23.5	80%	177	19.1	76%	177	18.1	72%	172	18.3
	2500	22.5	76%	174	18.1	72%	174	17.1	68%	169	17.6
	2500	21.5	72%	170	17.0	68%	170	16.1	64%	165	16.9
	2500	20.5	67%	166	15.9	64%	166	15.1	60%	161	16.1
	2500	19.5	63%	162	14.9	59%	162	14.1	56%	157	15.3

CIRRUS PILOT CHECKLIST

MODEL SR22

Press Alt			ISA - 30°C			ISA			ISA + 30°C		
	RPM	MAP	PWR	KTAS	GPH	PWR	KTAS	GPH	PWR	KTAS	GPH
8000	2700	21.7	83%	183	19.7	78%	183	18.6	75%	178	17.7
	2600	21.7	79%	180	18.8	75%	180	17.8	71%	175	17.0
	2500	21.7	75%	176	17.7	71%	176	16.8	67%	171	16.0
	2500	20.7	70%	172	16.7	66%	172	15.8	63%	167	15.0
	2500	19.7	66%	168	15.6	62%	168	14.8	59%	163	14.0
	2500	18.7	61%	163	14.5	58%	163	13.8	55%	158	13.1
	2500	17.7	57%	159	13.5	54%	159	12.8	51%	153	12.1
10000	2700	20.0	77%	182	18.2	73%	182	17.3	69%	176	16.4
	2600	20.0	71%	177	17.0	68%	177	16.1	64%	172	15.3
	2500	20.0	67%	173	16.0	64%	173	15.1	61%	167	14.4
	2500	19.0	63%	168	14.9	59%	168	14.1	56%	163	13.4
	2500	18.0	58%	163	13.8	55%	163	13.1	52%	158	12.5
	2500	17.0	54%	158	12.8	51%	158	12.1	48%	153	11.5
12000	2700	18.5	71%	180	16.9	67%	180	16.0	64%	175	15.2
	2600	18.5	68%	177	16.2	64%	177	15.3	61%	172	14.5
	2500	18.5	64%	173	15.2	60%	173	14.4	58%	167	13.7
	2500	17.5	59%	168	14.1	56%	168	13.4	53%	162	12.7
	2500	16.5	55%	162	13.0	52%	162	12.3	49%	157	11.7
	2500	15.5	50%	156	12.0	48%	156	11.3	45%	151	10.8
14000	2700	17.1	66%	178	15.6	62%	178	14.8	59%	173	14.1
	2600	17.1	63%	175	14.9	60%	175	14.1	57%	170	13.5
	2500	17.1	59%	171	14.1	56%	171	13.3	53%	165	12.7
	2500	16.1	55%	165	13.0	52%	165	12.3	49%	159	11.7
	2500	15.1	50%	159	11.9	47%	159	11.2	45%	153	10.7
16000	2700	15.8	61%	176	14.5	58%	176	13.7	55%	171	13.0
	2600	15.8	58%	173	13.8	55%	173	13.1	52%	167	12.5
	2500	15.8	55%	168	13.0	52%	168	12.3	49%	163	11.7
	2500	14.8	50%	162	11.9	47%	162	11.3	45%	156	10.7
17000	2700	15.2	59%	175	13.9	55%	175	13.2	53%	169	12.5
	2600	15.2	56%	171	13.3	53%	171	12.6	50%	166	12.0
	2500	15.2	53%	167	12.5	50%	167	11.9	47%	162	11.3
	2500	14.2	48%	160	11.4	45%	160	10.8	43%	155	10.3

CRUISE

CIRRUS PILOT CHECKLIST

MODEL SR22

Landing Distance

PRESS ALT FT		DISTANCE FT	TEMPERATURE ~ °C					ISA
			0	10	20	30	40	
WEIGHT = 3400 LB Speed over 50 Ft Obstacle = 77 KIAS Flaps - 100%· Idle · Dry, Level Paved Surface		Headwind: Subtract 10% for each 13 knots headwind.						
		Tailwind: Add 10% for each 2 knots tailwind up to 10 knots.						
		Runway Slope: Ref. Factors.						
		Dry Grass: Add 20% to Ground Roll						
		Wet Grass: Add 60% to Ground Roll						
SL	Grnd Roll	1082	1121	1161	1200	1240	1141	
	Total	2262	2316	2372	2428	2485	2344	
1000	Grnd Roll	1122	1163	1204	1245	1286	1175	
	Total	2317	2374	2433	2492	2551	2391	
2000	Grnd Roll	1163	1206	1248	1291	1334	1210	
	Total	2375	2436	2497	2559	2621	2441	
3000	Grnd Roll	1207	1251	1295	1339	1384	1247	
	Total	2437	2501	2565	2630	2696	2493	
4000	Grnd Roll	1252	1298	1344	1390	1436	1285	
	Total	2503	2569	2637	2705	2774	2548	
5000	Grnd Roll	1300	1348	1395	1443	1490	1324	
	Total	2572	2642	2713	2785	2857	2605	
6000	Grnd Roll	1350	1399	1449	1498	1547	1365	
	Total	2645	2719	2794	2869	2945	2665	
7000	Grnd Roll	1402	1453	1504	1556	1607	1408	
	Total	2723	2800	2879	2958	3038	2728	
8000	Grnd Roll	1456	1509	1563	1616	1669	1452	
	Total	2805	2887	2969	3052	3136	2794	
9000	Grnd Roll	1513	1569	1624	1679	1735	1497	
	Total	2892	2978	3064	3152	3240	2863	
10000	Grnd Roll	1573	1630	1688	1746	1803	1545	
	Total	2984	3074	3165	3257	3350	2936	

LANDING

Wind Components

Conditions:

- Runway Heading 10°
- Wind Direction 60°
- Wind Velocity 15 Knots

Example: (See Chart ▶ ▶ ▶)

- Wind/Flight Path Angle 50°
- Crosswind Component 12 Knots
- Headwind Component 10 Knots

• Note •

The maximum demonstrated crosswind is 20 knots. Value not considered limiting.

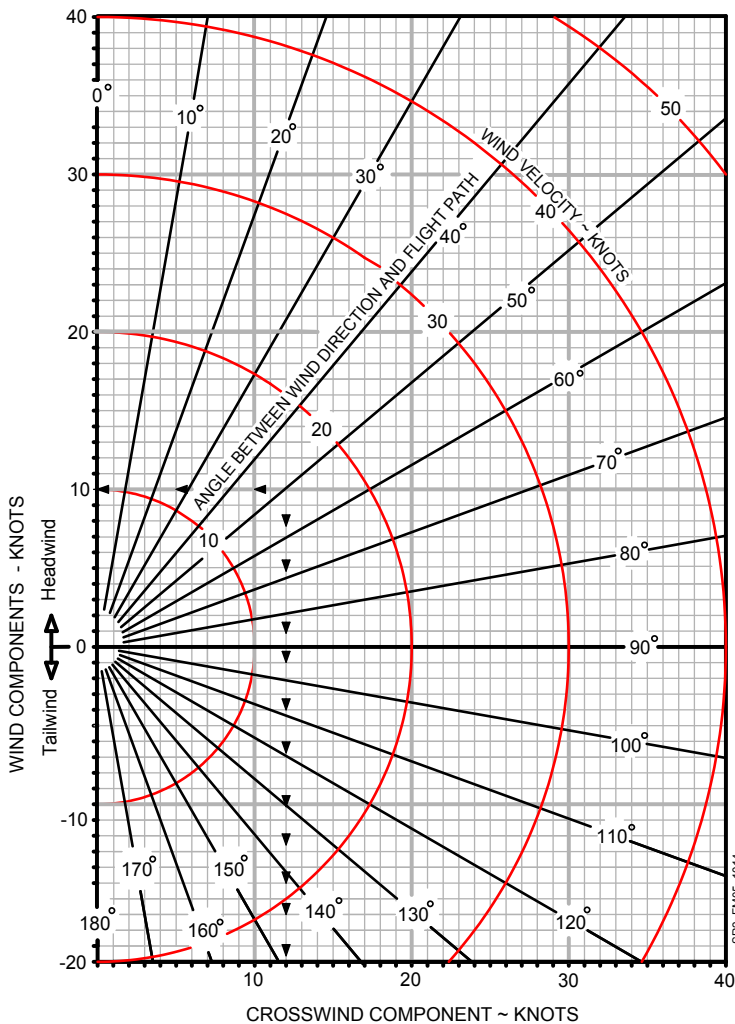

WIND COMPONENTS

CIRRUS PILOT CHECKLIST

MODEL SR22

Weight and Balance**Loading Calculations**

For Moment/1000, refer to Loading Data table on following page.

Description	Weight	Moment/1000
1. Empty Weight Includes unusable fuel and full oil		
2. Front Seats Occupants Pilot and Passenger		
3. Rear Seats Occupants		
4. Baggage 130 lb maximum		
5. Zero Fuel Condition Subtotal items 1 thru 4		
6. Fuel Load 81 Gallon @6.0 lb/gal. maximum		
7. Ramp Weight Subtotal items 5 and 6		
8. Fuel for start, taxi, and runup Normally 9 lb at avg. mmnt of 1394	-	-
9. Takeoff Weight Subtract Item 8 from item 7		

Calculation Instructions

1. Enter the current basic empty weight and moment from the aircraft's Weight and Balance Record.
2. Enter the total weight and moment/1000 for the front seat occupants from the adjacent Loading Data Table.
3. Enter the total weight and moment/1000 for the rear seat occupants from the adjacent Loading Data Table.
4. Enter the total weight and moment/1000 for the baggage from the adjacent Loading Data Table.
5. If desired, subtotal the weight and moment/1000 entries from steps 1 - 4.
6. Enter the weight and moment/1000 of usable fuel loaded on the airplane.
7. Subtotal the weight and moment/1000.
8. Enter values for typical start, taxi, and run-up operations of 9 pounds at an average moment/1000 of 1.39.
9. Subtract step 8 weight and moment/1000 from the Ramp Weight to determine the Takeoff Weight and moment/1000.
 - a. Verify Takeoff Weight does not exceed the 3400 pounds.
 - b. Verify Moment/1000 does falls between the interpolated minimum and maximum values listed on the adjacent Moment Limits Table.

CIRRUS PILOT CHECKLIST

MODEL SR22

Loading Data

To complete Loading Calculations, use this table to determine the Moment/1000.

Weight LB	Fwd Pass FS 143.5	Aft Pass FS 180.0	Baggage FS 208.0	Fuel FS 154.9	Weight LB	Fwd Pass FS 143.5	Aft Pass FS 180.0	Fuel FS 154.9
20	2.87	3.60	4.16	3.10	260	37.31	46.80	40.27
40	5.74	7.20	8.32	6.20	280	40.18	50.40	43.37
60	8.61	10.80	12.48	9.29	300	43.05	54.00	46.47
80	11.48	14.40	16.64	12.39	320	45.92	57.60	49.57
100	14.35	18.00	20.80	15.49	340	48.79	61.20	52.67
120	17.22	21.60	24.96	18.59	360	51.66	64.80	55.76
140	20.09	25.20	(27.04)*	21.69	380	54.53	68.40	58.86
160	22.96	28.80		24.78	400	57.40	72.00	61.96
180	25.83	32.40		27.88	420	60.27	75.60	65.06
200	28.70	36.00		30.98	440	63.14	79.20	68.16
220	31.57	39.60		34.08	460			71.25
240	34.44	43.20		37.18	486**			75.28

* 130 lb Maximum
 ** 81 Gallon Usable

Moment Limits

Use this table to determine if Loading Calculations are within limits.

Weight LB	Minimum Moment /1000	Maximum Moment/1000	Weight LB	Minimum Moment /1000	Maximum Moment/1000
2200	304	326	2850	398	422
2250	311	333	2900	406	430
2300	318	341	2950	414	437
2350	326	348	3000	421	444
2400	333	355	3050	429	452
2450	340	363	3100	437	459
2500	347	370	3150	444	467
2550	354	378	3200	452	474
2600	362	385	3250	460	481
2650	369	392	3300	467	489
2700	375	400	3350	475	496
2750	383	407	3400	483	504
2800	390	415			

WEIGHT AND BALANCE

CIRRUS PILOT CHECKLIST

MODEL SR22

Temperature Conversion

To convert from Celsius (°C) to Fahrenheit (°F), find, in the shaded columns, the number representing the temperature value (°C) to be converted. The equivalent Fahrenheit temperature is read to the right.

▶ EXAMPLE: 38°C = 100°F.

To convert from Fahrenheit (°F) to Celsius (°C), find in the shaded columns area, the number representing the temperature value (°F) to be converted. The equivalent Celsius temperature is read to the left.

▶ EXAMPLE: 38°F = 3°C.

Temp to Convert °C or °F			Temp to Convert °C or °F			Temp to Convert °C or °F		
°C	◀ ▶	°F	°C	◀ ▶	°F	°C	◀ ▶	°F
-50	-58	-72	-17	2	36	17	62	144
-49	-56	-69	-16	4	39	18	64	147
-48	-54	-65	-14	6	43	19	66	151
-47	-52	-62	-13	8	46	20	68	154
-46	-50	-58	-12	10	50	21	70	158
-44	-48	-54	-11	12	54	22	72	162
-43	-46	-51	-10	14	57	23	74	165
-42	-44	-47	-9	16	61	24	76	169
-41	-42	-44	-8	18	64	26	78	172
-40	-40	-40	-7	20	68	27	80	176
-39	-38	-36	-6	22	72	28	82	180
-38	-36	-33	-4	24	75	29	84	183
-37	-34	-29	-3	26	79	30	86	187
-36	-32	-26	-2	28	82	31	88	190
-34	-30	-22	-1	30	86	32	90	194
-33	-28	-18	0	32	90	33	92	198
-32	-26	-15	1	34	93	34	94	201
-31	-24	-11	2	36	97	36	96	205
-30	-22	-8	3	38	100	37	98	208
-29	-20	-4	4	40	104	38	100	212
-28	-18	0	6	42	108	39	102	216
-27	-16	3	7	44	111	40	104	219
-26	-14	7	8	46	115	41	106	223
-24	-12	10	9	48	118	42	108	226
-23	-10	14	10	50	122	43	110	230
-22	-8	18	11	52	126	44	112	234
-21	-6	21	12	54	129	46	114	237
-20	-4	25	13	56	133	47	116	241
-19	-2	28	14	58	136	48	118	244
-18	0	32	16	60	140	49	120	248

CIRRUS PILOT'S CHECKLIST MODEL SR22

Abnormal Procedures

Table of Contents

Ground Procedures.....	A-1
Brake Failure During Taxi.....	A-1
Aborted Takeoff.....	A-1
In-Flight Procedures.....	A-2
Inadvertent Icing Encounter.....	A-2
Inadvertent IMC Encounter.....	A-2
Door Open In Flight.....	A-2
Landing Procedures.....	A-3
Landing With Failed Brakes.....	A-3
Landing With Flat Tire.....	A-3
System Malfunctions.....	A-4
Alternator Failure.....	A-4
Engine Indicating System Failure.....	A-4
LOW VOLTS Warning Light Illuminated.....	A-5
Communications Failure.....	A-5
Pitot Static Malfunction.....	A-5
Electric Trim/Autopilot Failure.....	A-5

CIRRUS PILOT CHECKLIST MODEL SR22

Ground Procedures

Brake Failure During Taxi

- 1. Engine Power.....AS REQUIRED
- 2. Directional Control MAINTAIN WITH RUDDER
- 3. Brake Pedal(s) PUMP
If directional control can not be maintained:
- 4. Mixture CUTOFF

Aborted Takeoff

- 1. Power Lever IDLE
- 2. Brakes AS REQUIRED

In-Flight Procedures

Inadvertent Icing Encounter

1. Pitot Heat..... ON
2. Exit icing conditions. Turn back or change altitude.
3. Cabin Heat..... MAXIMUM
4. Windshield Defrost FULL OPEN
5. Alternate Induction Air ON

Inadvertent IMC Encounter

1. Airplane Control..... Establish Straight and Level Flight
2. Autopilot..... Engage to hold Heading and Altitude
3. Heading Reset to initiate 180° turn

Door Open In Flight

1. Airplane Control..... MAINTAIN

IN FLIGHT

Landing Procedures

Landing With Failed Brakes

One brake inoperative

1. Land on the side of runway corresponding to the inoperative brake.
2. Maintain directional control using rudder and working brake.

Both brakes inoperative

1. Divert to the longest, widest runway with the most direct headwind.
2. Land on downwind side of the runway.
3. Use the rudder for obstacle avoidance.
4. Perform *Emergency Engine Shutdown on Ground* checklist.

Landing With Flat Tire

Main Gear

1. Land on the side of the runway corresponding to the good tire.
2. Maintain directional control with the brakes and rudder.
3. Do not taxi. Stop the airplane and perform a normal engine shutdown.

Nose Gear

1. Land in the center of the runway.
2. Hold the nosewheel off the ground as long as possible.
3. Do not taxi. Stop the airplane and perform a normal engine shutdown.

System Malfunctions

Alternator Failure

ALT 1 Light Steady

1. ALT 1 Master Switch..... OFF
2. Alternator 1 Circuit BreakerCHECK and RESET
3. ALT 1 Master Switch..... ON
If alternator does not reset:
4. Switch off unnecessary equipment on Main Bus 1, Main Bus 2, and the Non-Essential Buses to reduce loads. Monitor voltage.
5. ALT 1 Master Switch..... OFF
6. Land as soon as practical.

ALT 1 Light Flashing

Serials 0002 thru 1643 and 1645 thru 1666:

1. Ammeter SwitchBATT
2. If charging rate is greater than 30 amps, reduce load on Main Bus 1, Main Bus 2, and Non-Essential buses.
3. Monitor ammeter until battery charge rate is less than 15 amps.
4. When battery charge rate is within limits, add loads as necessary for flight conditions.

ALT 2 Light Steady

1. ALT 2 Master Switch..... OFF
2. Alternator 2 Circuit BreakerCHECK and RESET
3. ALT 2 Master Switch..... ON
If alternator does not reset:
4. Switch off unnecessary equipment on Main Bus 1, Main Bus 2, and Non-Essential Buses to reduce loads.
5. ALT 2 Master Switch..... OFF
6. Land as soon as practical.

Engine Indicating System Failure

Serials 1644, 1663 and Subsequent:

1. ANNUN / ENGINE INST Circuit Breaker Cycle
2. Land as soon as practical.

LOW VOLTS Warning Light Illuminated

1. Land as soon as practical.

Communications Failure

1. Switches, ControlsCHECK
2. Frequency CHANGE
3. Circuit BreakersCHECK
4. Headset CHANGE
5. Hand Held MicrophoneCONNECT

Pitot Static Malfunction

Static Source Blocked

1. Pitot Heat ON
2. Alternate Static Source OPEN

Pitot Tube Blocked

1. Pitot Heat ON

Electric Trim/Autopilot Failure

1. Airplane Control MAINTAIN MANUALLY
2. Autopilot (if engaged) Disengage

If Problem Is Not Corrected:

3. Circuit Breakers PULL AS Required
 - PITCH TRIM
 - ROLL TRIM
 - AUTOPILOT
4. Power LeverAS REQUIRED
5. Control YokeMANUALLY HOLD PRESSURE
6. Land as soon as practical.

SYSTEMS

CIRRUS PILOT'S CHECKLIST MODEL SR22

Emergency Procedures

Table of Contents

Airspeeds For Emergency Operations	E-1
Maximum Glide.....	E-1
Memory Items.....	E-1
Ground Emergencies	E-2
Engine Fire During Start	E-2
Emergency Engine Shutdown On Ground	E-2
Emergency Ground Egress	E-2
In-Flight Emergencies	E-3
Engine Failure On Takeoff (Low Altitude).....	E-3
Engine Failure In Flight.....	E-3
Engine Airstart	E-4
Engine Partial Power Loss	E-4
Low Oil Pressure	E-4
Propeller Governor Failure	E-4
Smoke and Fume elimination	E-5
Engine Fire In Flight	E-5
Wing Fire In Flight	E-5
Cabin Fire In Flight	E-5
Emergency Descent	E-6
Inadvertent Spiral Dive During IMC Flight	E-6
Inadvertent Spin Entry	E-6
CAPS Deployment.....	E-7
Landing Emergencies	E-8
Emergency Landing Without Engine Power	E-8
Ditching.....	E-8
Landing Without Elevator Control.....	E-8
System Malfunctions	E-9
PFD - Loss of Air Data.....	E-9
PFD - Loss of Attitude Data.....	E-9
Power Lever Linkage Failure.....	E-9
Annunciator Panel / MFD EMAX Messages	E-10
Circuit Breaker Panel	E-11

CIRRUS

Airspeeds For Emergency Operations

Maneuvering Speed:

- 3400 lb..... 133 KIAS

Best Glide:

- 3400 lb..... 88 KIAS
- 2900 lb..... 87 KIAS

Emergency Landing (Engine-Out)

- Flaps Up 90 KIAS
- Flaps 50% 85 KIAS
- Flaps 100% 80 KIAS

Maximum Glide

Glide Ratio \approx 9.6 : 1

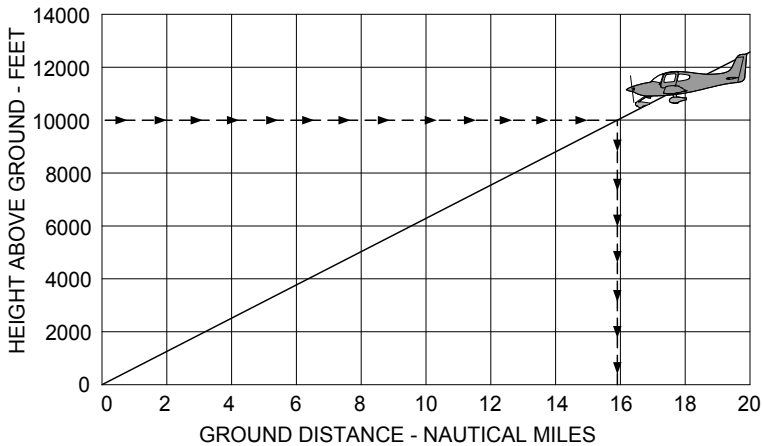

SR2_FM03_1391

Memory Items

Checklist steps emphasized by underlining such as the example below, should be memorized for accomplishment without reference to the procedure.

1. Best Glide Speed..... ESTABLISH

Ground Emergencies**Engine Fire During Start**

1. Mixture CUTOFF
2. Fuel Pump OFF
3. Fuel Selector OFF
4. Power Lever FORWARD
5. Starter CRANK
6. If flames persist, perform *Emergency Engine Shutdown on Ground* and *Emergency Ground Egress* checklists.

Emergency Engine Shutdown On Ground

1. Power Lever IDLE
2. Fuel Pump (if used) OFF
3. Mixture CUTOFF
4. Fuel Selector OFF
5. Ignition Switch OFF
6. Bat-Alt Master Switches OFF

Emergency Ground Egress

1. Engine SHUTDOWN
2. Seat belts RELEASE
3. Airplane EXIT

GROUND

In-Flight Emergencies**Engine Failure On Takeoff (Low Altitude)**

1. Best Glide or Landing Speed (as appropriate) ESTABLISH
2. Mixture CUTOFF
3. Fuel Selector OFF
4. Ignition Switch OFF
5. Flaps AS REQUIRED

If time permits:

6. Power Lever IDLE
7. Fuel Pump OFF
8. Bat-Alt Master Switches OFF
9. Seat Belts ENSURE SECURED

Engine Failure In Flight

1. Best Glide Speed ESTABLISH
2. Mixture AS REQUIRED
3. Fuel Selector SWITCH TANKS
4. Fuel Pump BOOST
5. Alternate Induction Air ON
6. Air Conditioner (if installed) OFF
7. Ignition Switch CHECK, BOTH
8. If no start, perform *Engine Airstart* or *Forced Landing* checklist.

CIRRUS PILOT CHECKLIST

MODEL SR22

Engine Airstart

1. Bat Master Switches ON
2. Power Lever ½" OPEN
3. Mixture RICH, AS REQ'D
4. Fuel Selector SWITCH TANKS
5. Ignition Switch BOTH
6. Fuel Pump BOOST
7. Alternate Induction Air ON
8. Alt Master Switches OFF
9. Starter (Propeller not Windmilling) ENGAGE
10. Power Lever slowly INCREASE
11. Alt Master Switches ON
12. If no start, perform *Forced Landing* checklist.

Engine Partial Power Loss

1. Air Conditioner (if installed) OFF
2. Fuel Pump BOOST
3. Fuel Selector SWITCH TANKS
4. Mixture CHECK appropriate for flight conditions
5. Power Lever SWEEP
6. Alternate Induction Air ON
7. Ignition Switch BOTH, L, then R
8. Land as soon as practical.

Low Oil Pressure

1. Power Lever MINIMUM REQUIRED
2. Land as soon as possible.

Propeller Governor Failure***Propeller Rpm Will Not Increase***

1. Oil Pressure CHECK
2. Land as soon as practical.

Propeller Overspeeds Or Will Not Decrease

1. Power Lever ADJUST (to keep RPM in limits)
2. Airspeed REDUCE to 90 KIAS
3. Land as soon as practical.

Smoke and Fume elimination

1. Air Conditioner (if installed) OFF
2. Temperature Selector COLD
3. Vent Selector FEET/PANEL/DEFROST POSITION
4. Airflow Selector SET AIRFLOW TO MAXIMUM
If source of smoke and fume is firewall forward:
 - a. Airflow Selector OFF
5. Panel Eyeball Outlets OPEN
6. Prepare to land as soon as possible.
If airflow is not sufficient to clear smoke or fumes from cabin:
 - a. Cabin Doors PARTIALLY OPEN

Engine Fire In Flight

1. Mixture CUTOFF
2. Fuel Pump OFF
3. Fuel Selector OFF
4. Airflow Selector OFF
5. Power Lever IDLE
6. Ignition Switch OFF
7. Cabin Doors PARTIALLY OPEN
8. Land as soon as possible.

Wing Fire In Flight

1. Pitot Heat Switch OFF
2. Navigation Light Switch OFF
3. Landing Light OFF
4. Strobe Light Switch OFF
5. If possible, side slip to keep flames away from fuel tank and cabin.
6. Land as soon as possible.

Cabin Fire In Flight

Warning: *Serials 0435 and subsequent with PFD:* If in IMC conditions, turn ALT 1, ALT 2, and BAT 1 switches OFF. Power from battery 2 will keep the PFD operational for about 30 minutes.

1. Bat-Alt Master Switches OFF, AS REQ'D

CIRRUS PILOT CHECKLIST MODEL SR222. Heater..... OFF3. Air VentsCLOSED4. Fire Extinguisher.....ACTIVATE*If airflow is not sufficient to clear smoke or fumes from cabin:*5. Cabin Doors.....PARTIALLY OPEN6. When fire extinguished, Air Vents..... OPEN, FULL COLD

7. Avionics Power Switch..... OFF

8. All other switches..... OFF

9. Land as soon as possible.

If setting master switches off eliminated source of fire or fumes and airplane is in night, weather, or IFR conditions:

10. Bat-Alt Master Switches ON

11. Avionics Power Switch..... ON

12. Activate required systems one at a time. Activate only the minimum amount of equipment necessary to complete a safe landing.

Emergency Descent1. Power Lever..... IDLE2. Mixture.....AS REQUIRED3. Airspeed V_{NE} (201 KIAS)**Inadvertent Spiral Dive During IMC Flight**1. Power Lever..... IDLE2. Stop the spiral dive by using coordinated aileron and rudder control while referring to the attitude indicator and turn coordinator to level the wings.3. Cautiously apply elevator back pressure to bring airplane to level flight attitude.

4. Trim for level flight.

5. Set power as required.

6. Use autopilot if functional otherwise keep hands off control yoke, use rudder to hold constant heading.

7. Exit IMC conditions as soon as possible.

Inadvertent Spin Entry1. CAPS.....ACTIVATE

CAPS Deployment

1. Airspeed MINIMUM POSSIBLE

The maximum demonstrated deployment speed is 133 KIAS.

2. Mixture (If time and altitude permit) CUTOFF

3. Activation Handle Cover REMOVE

4. Activation Handle..... PULL STRAIGHT DOWN

Pull activation T-handle from its holder. Clasp both hands around the handle and pull straight down in a strong, steady, and continuous motion. Maintain maximum pull force until the rocket activates. Pull forces up to, or exceeding, 45 pounds may be required. Bending of the handle-housing mount is to be expected.

Warning: Jerking or rapidly pulling on the activation T-handle will greatly increase the pull forces required to activate rocket. Use a firm and steady pulling motion - a “chin-up” type pull enhances successful activation.

After deployment:

5. Mixture CHECK, CUTOFF

6. Fuel Selector OFF

7. Bat-Alt Master Switches OFF

8. Ignition Switch OFF

9. Fuel Pump OFF

10. ELT ON

11. Seat Belts and Harnesses TIGHTEN

12. Loose Items SECURE

13. Assume emergency landing body position.

14. After airplane comes to a complete stop, evacuate quickly and move upwind.

Landing Emergencies

Emergency Landing Without Engine Power

1. Best Glide Speed..... ESTABLISH
2. Radio Transmit (121.5 MHz) MAYDAY
3. Transponder..... SQUAWK 7700
4. If off airport, ELTACTIVATE
5. Power Lever..... IDLE
6. Mixture..... CUTOFF
7. Fuel Selector OFF
8. Ignition Switch OFF
9. Fuel Pump OFF
10. Flaps (when landing is assured)..... 100%
11. Master Switches OFF
12. Seat Belt(s)..... SECURED

Ditching

1. Radio Transmit (121.5 MHz) MAYDAY
giving location and intentions
2. Transponder..... SQUAWK 7700
3. CAPS.....ACTIVATE

If available, life preservers should be donned and life raft should be prepared for immediate evacuation upon touchdown.

Consider unlatching a door prior to assuming the emergency landing body position in order to provide a ready escape path.

4. AirplaneEVACUATE
It may be necessary to allow some cabin flooding to equalize pressure on the doors. If the doors cannot be opened, break out the windows with the egress hammer and crawl through the opening.
5. Flotation Devices INFLATE WHEN CLEAR OF AIRPLANE

Landing Without Elevator Control

1. Flaps..... SET 50%
2. Trim..... SET 80 KIAS
3. Power..... AS REQUIRED FOR GLIDE ANGLE

System Malfunctions**PFD - Loss of Air Data**

1. Land as soon as practical.
2. Standby Instruments (altitude, airspeed)..... MONITOR
If failure occurs while flying in IMC:
3. Exit IMC.

PFD - Loss of Attitude Data

1. Standby Instruments (attitude, heading)..... MONITOR
If failure occurs while flying in IMC:
2. Autopilot GPSS Mode.....ACTIVATE
3. Autopilot Altitude HoldACTIVATE
4. Exit IMC.

Power Lever Linkage Failure

1. Power Lever Movement VERIFY
2. Power SET if able
3. Flaps SET if needed
4. Mixture AS REQUIRED (full rich to cut-off)
5. Land as soon as possible.

Annunciator Panel / MFD EMAX Messages

Engine Speed > 2710 RPM for 5s:

Check RPM

A
C
KOil Temperature $\geq 240^{\circ}\text{F}$:

Check Oil Temp

A
C
K

Oil Pressure < 10 psi OR > 99 psi:

Check Oil Press

A
C
KCylinder Head Temperature > 460°F :

Check CHT

A
C
K

Main Bus Volts < 24.5v OR > 32.0v:

Check Main Bus

A
C
K

Essential Bus Volts < 24.5v OR > 32.0v:

Check Essential Bus

A
C
K

Fuel Flow > 30.0 gallons per hour:

Check Fuel Flow

A
C
K

Fuel Remaining < 9.9 gallons:

Check Fuel Remaining

A
C
KOil Temperature $\geq 235^{\circ}\text{F}$:

Monitor Oil Temp

A
C
K

Oil Pressure < 30 psi OR > 75 psi:

Check Oil Press

A
C
KCylinder Head Temperature > 420°F :

Check CHT

A
C
K

Alternator 1 < 2 A for 20 s or more:

Check Alt 1

A
C
K

Alternator 2 < 2 A for 20 s or more:

Check Alt 2

A
C
K

Battery 1 < -4 A for 30 s or more:

Check Batt 1

A
C
K

Fuel Flow > 26.7 gallons per hour:

Check Fuel Flow

A
C
K

Fuel Remaining < 28.0 gallons:

Check Fuel Remaing

A
C
K

Low Fuel Condition

Each tank below approx. 14 gallons.

System Voltage Below 24.5v

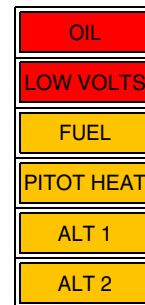
High Oil Temperature
OR Low Oil PressureFlashing: ALT 2 Overload
Steady: ALT 2 FailureFlashing: ALT 1 Overload
Steady: ALT 1 FailurePitot Switch "ON"
No Power to Pitot Mast

Circuit Breaker Panel

